

TH-8017

## Scaled Paperweight Magnifier

Size:140X82X37mm      Magnification:3X

- This product has the amplification function, assist in observing the object.
- Bright LED and UV Light, switch lights as need.
- The transparent cover can be removed and can be used in various ways.
- Accurate scale, clear reading, Min. Scale Division:0.5mm or 1/16inch.

### Function:

Stamp collecting, embroidery, antique, biological observation, reading, observation of electronic components, etc.

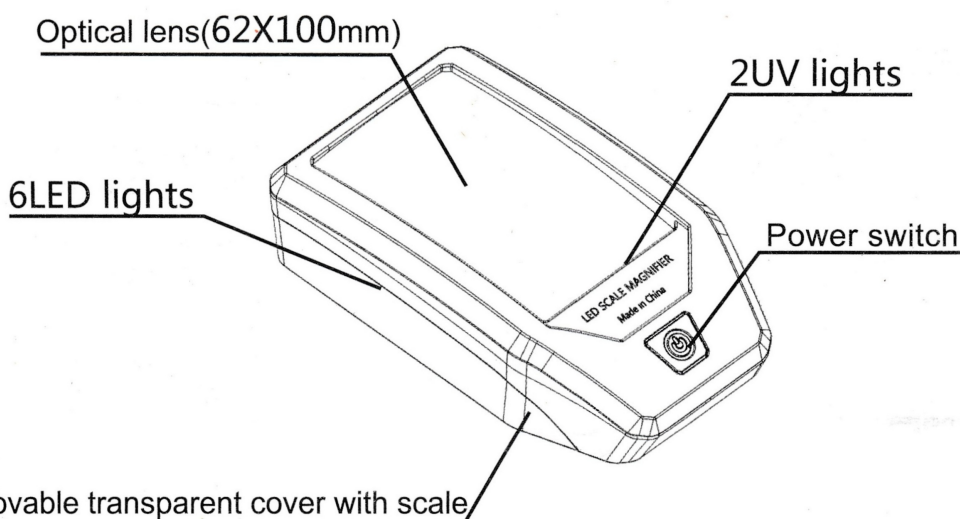

### Notes:

1. Please use soft cotton cloth to wipe lens, so as not to scratch the lens.
2. Please do not place the magnifying glass on the direct sunlight position to avoid fire.
3. Please do not use a magnifying glass to look directly at the sun

### Usage method:

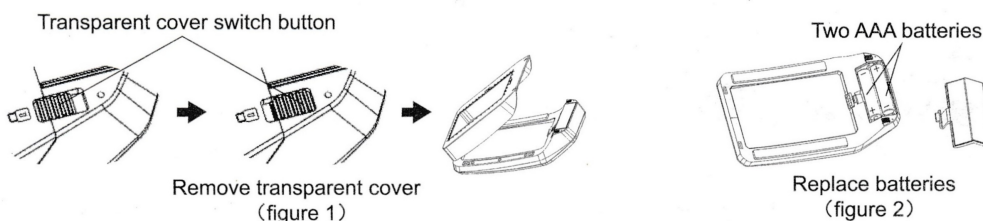

1. When using the paperweight, place the magnifying glass directly on the object and move it horizontally. In handheld use, the switch button of the transparent cover shall be unlocked and the transparent cover shall be removed (as shown in figure 1). then hold a magnifying glass over the object and adjust the distance and angle between the lens and the object until the image is large and clear.
2. LED functions: the first press White LED light work, pressing a second time UV light work, the third is off the light.
3. Use two AAA batteries and replace them by removing the transparent cover first and then the battery cover (as shown in figure 2), reload the new batteries as per the previous position.

### ▲ WARNING

If the product is not used for a long time, please remove the battery.  
This product has been applied for patent, counterfeiting will be prosecuted  
Patent application no :201930590857. 7